

# ACCUPIER<sup>®</sup> SUPPORT SYSTEM

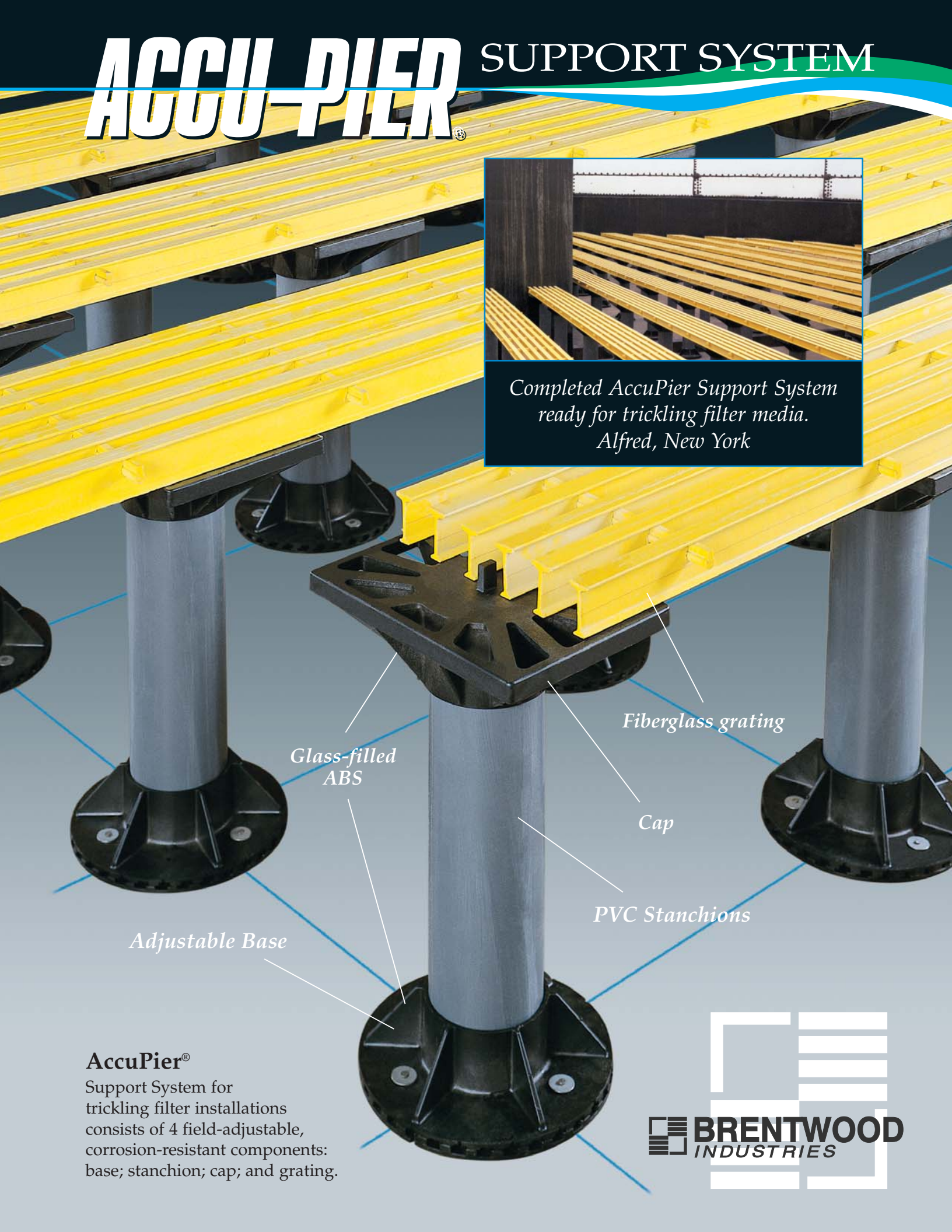

*Completed AccuPier Support System  
ready for trickling filter media.  
Alfred, New York*



*Glass-filled  
ABS*

*Fiberglass grating*

*Cap*

*PVC Stanchions*

*Adjustable Base*

## **AccuPier<sup>®</sup>**

Support System for trickling filter installations consists of 4 field-adjustable, corrosion-resistant components: base; stanchion; cap; and grating.



AccuPier  
COMPRESSION  
TESTED TO  
**24,000 lbs**  
(10,900 kg)

AccuPier® is a pre-engineered support system for trickling filter media. A field-adjustable base and cut-to-length stanchions allow installation in a variety of tank configurations. All components are engineered plastics for corrosion-resistance and ease-of-installation. A complete system consists of adjustable base, stanchion, cap, and grating. AccuPier was designed to replace formed-in-place concrete supports and heavy concrete crossbeams.

### ENGINEERED COMPONENTS

- Adjustable base accommodates any floor slope up to 4%
- Pier heights variable from 8" (20 cm) to 60" (150 cm)
- Rated to hold 7,000 lbs. (3180 kg) per pier
- Complete system, including pier spacing and grating load, are engineered by Brentwood for a specific application
- Seismic Zone 4 design available

### COMPLETE SUPPORT SYSTEM SOLUTION

- Allows maximum airflow and wastewater flow through plenum
- Less expensive than conventional poured concrete supports and pre-cast beams
- Practical solution for both rock filter retrofits and deep towers
- Quick and easy installation

### INSTALLATION (in 6 easy steps)



- 1 Lay out grid pattern on tank floor
- 2 Locate and level bases
- 3 Anchor base with powder-actuated nail gun
- 4 Measure and cut stanchion to length
- 5 Solvent-bond base, stanchion, and cap
- 6 Place grating on piers.

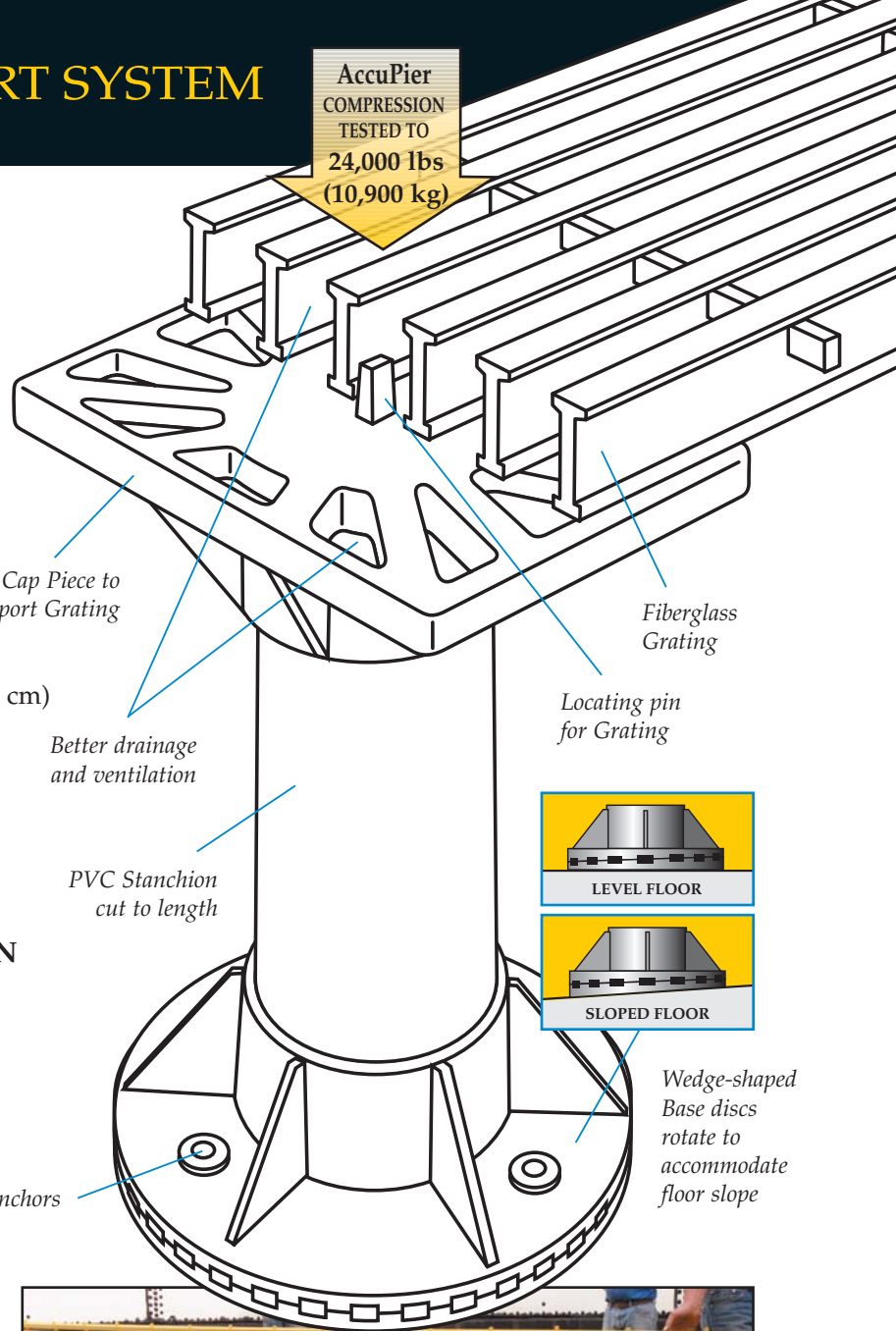

**BRENTWOOD**  
INDUSTRIES

Brentwood Industries, Inc.

Mailing Address P.O. Box 605, Reading, PA 19603, USA

Shipping Address 610 Morgantown Road, Reading, PA 19611

Phone 610.236.1100 Fax 610.736.1280

Email [wwsales@brentwoodindustries.com](mailto:wwsales@brentwoodindustries.com)

Website [www.BrentwoodProcess.com](http://www.BrentwoodProcess.com)